



RENAULT TRUCKS E-Tech C

reault-trucks.co.uk

 RENAULT TRUCKS
E-TECH



**RENAULT
TRUCKS**

Make the switch to electric mobility smoothly with Renault Trucks



Renault Trucks, the expert partner for your decarbonisation journey

As professionals in the haulage sector, you need solid and dependable support in the switch to electromobility. Renault Trucks is by your side throughout your decarbonisation plan, providing support based on experience.

We have been producing and selling electric vehicles for over 10 years, and our Renault Trucks E-Tech range has covered more than 15 million kilometres. Renault Trucks E-Tech D and Renault Trucks E-Tech D Wide have been in production since 2020 at our Blainville production facility in France.

Our experts are specialists and undergo continuous training to ensure your energy transition is a success.

With their knowledge in light commercial and heavy commercial vehicles, they are best-qualified to support you in your transition to electromobility.

Together, we are moving forward with simplicity, pragmatism, warmth and commitment.

#JoinTheGoodMove



More than
15 000 000
kilometres

covered by our current
Renault Trucks E-Tech range*

*End of April 2024

Our support milestones for your electric transition

We make sure you can reach your CO₂ emission reduction objectives, continue your daily business and optimise your TCO*.

*Total Cost of Ownership

From pre-sale to operation, our experts support you on your decarbonisation journey in four steps



Our local Energy Transition specialists will be with you at every step of your your transition to electric



Renault Trucks is by your side at every step

STEP 1 We understand your needs

1

We actively listen to your needs for decarbonizing road freight and provide detailed explanations of the various available options.



We take ownership of your objectives

Have you made a commitment to decrease your CO₂ emissions? Are you required to comply with a forthcoming Low/Zero Emission Zone? Are your customers demanding a more environmentally friendly mode of transportation?

- We are committed to understanding your objectives and limitations, and we will prioritize them as our target.

We explain all options to decarbonise

There are various potential energy sources and technologies available (such as bio-energies, hydrogen, and electricity), and you are seeking to determine which ones best align with your specific needs?

- We will provide you with our comprehensive assessment for each option, outlining their respective impacts on CO₂ emissions, energy efficiency, total cost of ownership (TCO), and operational considerations.

STEP 2 We analyse your fleet and routes to predict your range

2

We use our Range Simulator to make sure your range need is covered and conduct an electric audit of your site.

We simulate your site energy consumption to fit with your fleet electrification.

We simulate your real operations to confirm your switch to electric

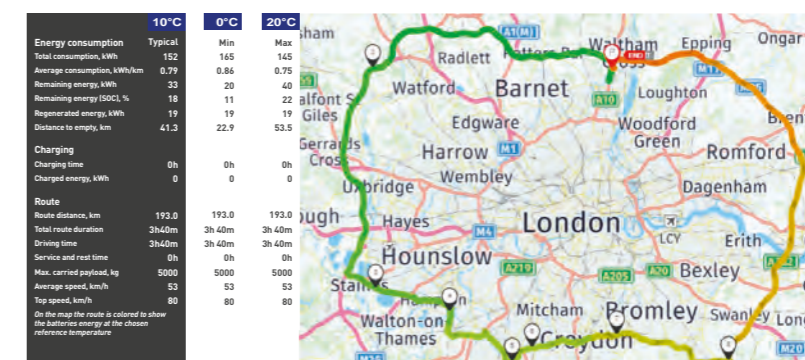

- Using our Range Simulator tool, our experts will assess the energy consumption of your vehicle, taking into account its actual usage, GPS route, and any factors that may affect its consumption (such as weather conditions, topography, and speed).
- The results, presented in a user-friendly and visually appealing manner, will provide you with a clear understanding of your vehicle's operation throughout the year and highlight the need for any intermediate charging solutions.

We work with experts in the industry to understand the available power on your site and plan for your charging infrastructure needs



STEP 3 We design your electric solution for urban construction

We create a complete offer: truck, charging, services and financing (including public incentives advice).



The Renault Trucks E-Tech C

- Is perfectly suited for your urban construction activities such as material distribution, aggregate delivery and road maintenance.
- Shows a significant reduction in CO₂ emissions equivalent of its life cycle of around 90% (depending on the vehicle configuration and on the country).
- Is a qualified solution to operate for:
 - Science Based Targets Initiative (SBTI)
 - Zero/Low Emission Zones
 - CO₂ regulated industries

A range up to 500 km

- Up to 300 km* range on a single charge and up to 500 km range thanks to an intermediate one-hour fast charge (250 kW).
- Average electrical consumption: 1 to 1.6 kWh/km.

*Actual range may depend on several factors, such as driving speed, use of cruise control, vehicle specifications, terrain topography, driver experience, vehicle maintenance and weather conditions.

Our truck is suitable for all types of charging up to 250 kW and equipped with a standard connector compatible with AC and DC chargers

CHARGING METHOD	WALLBOX MODE 3	CCS CONNECTOR** COMBO 2 MODE 4 MOBILE	CCS CONNECTOR** COMBO 2 MODE 4
Charger	AC	DC	DC
Charge power	43 kW	40 kW	Up to 250 kW*
Charger type	Built-in charger	Mobile charger	Fixed charger
Recommended use	Night-time charging	Only one 63-amp connector is required Mobile easy-to-use system	For several vehicles or when fast charging is required

*Charger compatible with higher power standards, but the power limit is set by the vehicle itself.
**CCS: combined charging system.

Fast charging time

- Only 1 hour charging from 20% to 80% battery capacity (with 6 battery packs, power charging of 250 kW).



An ergonomic driving position to offer you a unique and silent electric experience

1 Multifunction screen

- 9 inches HD touch screen
- Multiple applications for a personalized driving experience
 - Call management
 - Music control
- Driver aids (cameras, navigation)

2 Modern dashboard

- Dynamic, digital information display

3 Induction charger*

4 USB-C plugs

5 Storage space for documents

N/A with compact dash

6 Keyless vehicle starting using the start button

7 Smooth gear shifts thanks to the Optidriver gearbox

8 Smart direction indicator cancellation



9 Steering wheel

- Functionalities at your fingertips

The best steering column on the market

10 Multidirectional column

- 3 adjustable points, you can exactly adapt the driving position to your morphology
- Intuitive foot control on the steering column to determine your ideal driving position
- Easy access to the cab when the steering wheel is in the raised position



- More knee room

*Optional



image for illustration purposes only

With safety equipment



Radars and cameras

Located all around your truck, they warn you and alert you to ease your manoeuvres. You prevent any risks of accident.

Possibility to add up to 5 digital cameras to monitor the load or the fifth wheel for docking*.

Possibility to provide an analog camera for the trailer to monitor manoeuvres*.

*On request for adaptation



Lane Departure Warning System and Driver Drowsiness & Alertness Warning (LDWS/DDAW)

Audible and visual warning if a lane departure is detected or if the vehicle is following an unexpected trajectory.



Automatic Emergency Braking System (AEBS)

Warns of a possible collision, then brakes and stops the vehicle if no action from the driver.

The hazard warning lights are activated automatically.

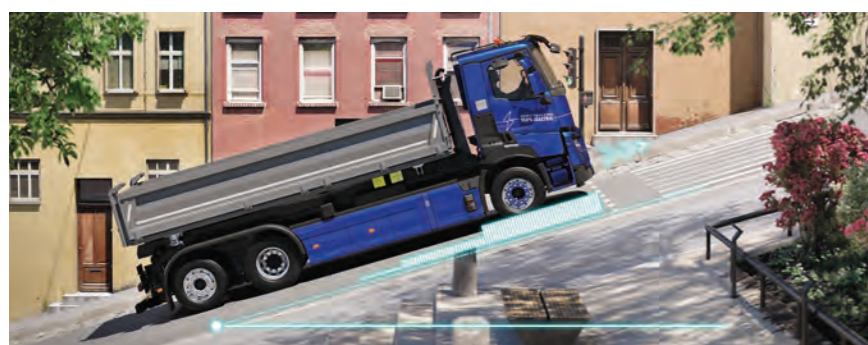

Hill start assist with Autohold

Automatically manages braking, when driver comes to a stop. The truck is immobilized until driver decides to take-off, preventing risks from rolling away accidentally.

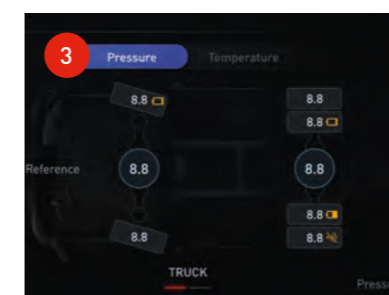
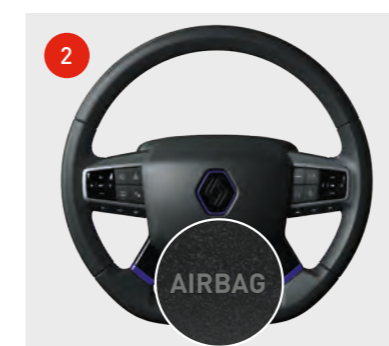

1 Automatic activation of headlights and windscreen wipers

→ Improves visibility and allows the driver to concentrate on the road.

2 Driver Airbag

→ The airbag is deployed in the event of a serious frontal collision.

3 Tyre Pressure Monitoring System (TPMS)

→ Sensors warn you and alert you on any problems about tire pressure, which provides you peace of mind.

4 Antirunaway mode

- Emergency parking brake application.
- Immobilisation of the vehicle when the door on the driver's side is opened.

5 Speed Assistance** (ISA***)

→ The camera recognises the prescribed speed limit and warns the driver if this is exceeded, to avoid any accidents or penalties.

**available depending on geographical location
***Intelligence Speed Assistant

6 Mechanical anti-intrusion locking*

→ For greater safety in the cab when the vehicle is parked.

*optional

Our charging solutions are adapted to your needs

Renault Trucks and their partners perform an audit of your on-site charging facilities to provide complete charging solutions and we are committed to support public charging deployment to reach maximum productivity and uptime.

Rely on our energy experts to adapt your electric infrastructure

- Get a detailed analysis of your current power and energy need.
- After your fleet analysis, an on-site power impact simulation is done with your electric trucks.
- Our professional electricity partners will build your new power roadmap and guide you on higher-capacity solutions.
- We ensure your new charging infrastructure is positioned based on your operational needs.



Choose upon our charging devices options

- For overnight charging, you can use an AC 43 kW wall-box.
- For more intensive charging requirements, we will connect with our partner's to get the best devices and supervision software.*

*List of compatible chargers available at the dealership.

Stay relaxed with our charging maintenance

- Our team and partners secure the right civil and electrical works on your site based on our analysis.
- Commissioning, specific trainings and 24/7 maintenance are included in your charging maintenance.*

*Ongoing maintenance subject to individual contracts as appropriate.

Rely on our strong commitment to deploy public charging

- Renault Trucks, as part of Volvo Group, is highly involved into the largest charging infrastructure investment in the European heavy-duty truck industry to date.
- 1700 charging points will be available by 2027 through Europe.

Tailored services to maximise uptime and peace of mind

Included during 8 years for every truck purchase:

On the good path with SYGIC navigation system ^{NEW} :

- Navigation dedicated to trucks.
- Always up-to-date.
- Data communication included.

Secure your routes and energy consumption with Optifleet

Optifleet CHECK*

Analyse the performance of your trucks thanks to reports including data on battery usage, power take-off (PTO) information, load, brake usage, energy consumption.

Optifleet DRIVE*

Allows you to download tachograph data remotely, so there is no need for vehicle downtime.

Optifleet MAP*

Monitor your trucks through:

- Real-time data: truck geolocation, speed indication, battery level, driver ID card, mileage.
- Advanced features: management of Points Of Interests (POIs) and geofencing capabilities, route history.

Optifleet MISSION* ^{NEW}

- Plan the best route for your electric truck, based on vehicle profile, transported load, initial battery level, road restrictions and anticipate the charging stops.
- Share the itinerary with your drivers; displayed on the truck multifunction screen.

*more capabilities information available at your dealer.



Ease your driving experience with Driver App ^{NEW}

- Serenity: charge monitoring with range left, estimated time for charging completion, state of charge, alerts in case of charging interruption.
- Safety: check doors lock and get alerts in case of intrusion.

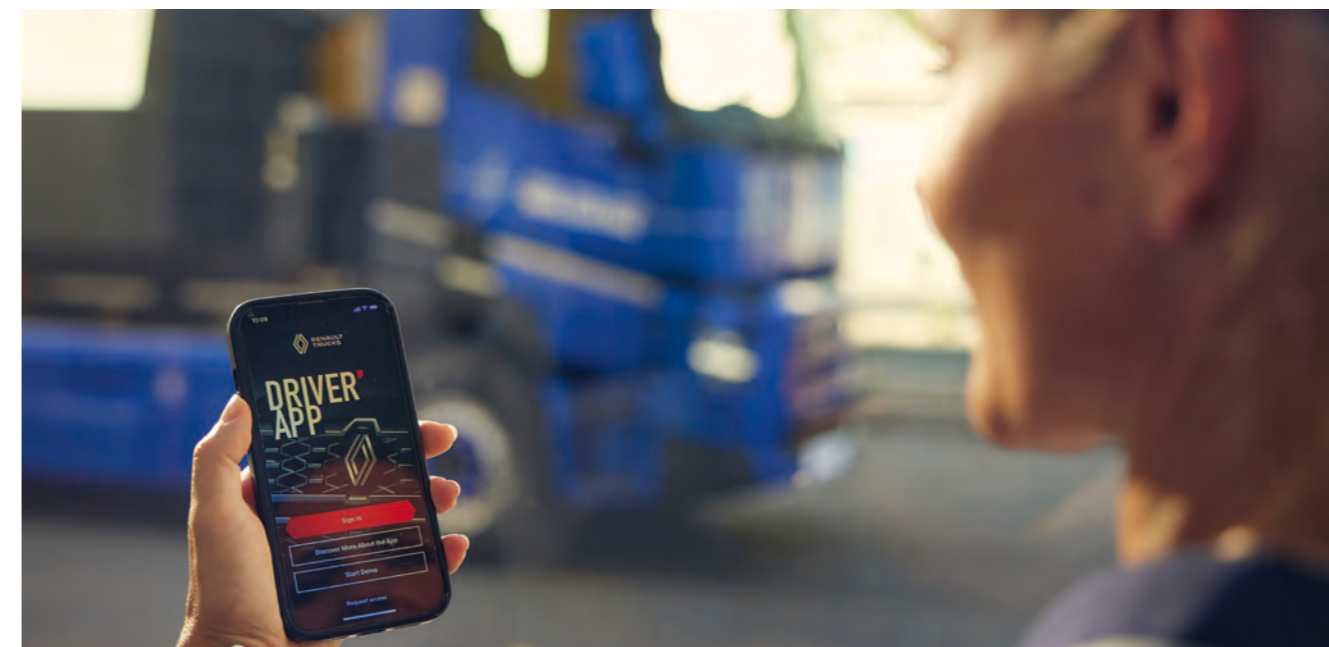

Ensure your uptime and productivity with our Serenity pack ^{NEW}

More than a maintenance and repair contract, benefit from predictive capabilities, as well as personalised reports and data support on the CO₂ & usage of your Renault Trucks E-Tech fleet.



*Support services period can be extended.

Tailored services to maximise uptime and peace of mind

Advice on optimising TCO and carbon footprint

Renault Trucks can help you to calculate the total cost of ownership (TCO) of your electric vehicle solution and evaluate the associated CO₂ savings. With our custom-built tool, the "TCO₂ Calculator", our experts can provide you with the best possible view of your transition to electromobility:



Get an understandable comparison

the closest possible view of the TCO of an electric truck compared to a diesel or gas truck.



Adjust the various factors that impact TCO

duration, miles/kilometres, energy cost, simulation of the different purchasing subsidies and tax breaks.



Calculate and compare CO₂ emissions

for the different energy sources over the lifetime of the vehicle, based on a variety of scenarios. The results of the simulation will give you a quick idea of the total expenses, energy costs and potential CO₂ reductions.

Finance your electric transition

Benefit from support tailored to your needs across all aspects of financing to facilitate your transition to electric vehicles.



Financing and subsidies

- Administrative support with governmental incentives*.
- Advice on suitable financing for electric vehicles.
- Possibility to include the financing of the charging infrastructure*.

With fixed monthly payments that include the vehicle, financing, maintenance contract and charging infrastructure, Renault Trucks Financial Services offers you the opportunity to switch smoothly to electric vehicles.

*Available depending on the country.



STEP 4 We support your implementation and operations

We monitor your truck efficiency, provide you with a comprehensive network and minimum energy availability commitment to maximise your uptime.

Benefit from a customised support during usage

Get an operational performance support

- We will support you in your first steps with your new electric trucks operational performance.

Understand usage of your electric trucks

- Our reports will help you understand the use of your truck to get the best out of it.

Build action plans

- During the first year of your Serenity pack, our experts will recommend optimized actions based on your fleet data.



Rely on our network and our energy commitment

With almost 1400 service points across Europe, there is always a dealer near you.

A Renault Trucks E-Tech certified network fully equipped, trained, close to you and always available

- Expert technicians trained in electrical solutions
- Extended opening hours, including Saturday mornings*
- Fast appointments for repairs and maintenance

*Depending on Renault Trucks authorised dealers.



Renault Trucks secures energy availability

With the Serenity pack, we ensure the full performance of your batteries and commit on a minimum amount of usable energy per full charge corresponding to **80% of SoH (State of Health)**. A battery's health monitoring is included in the predictive capabilities. Renault Trucks secures the energy availability from our batteries during a maximum of **10 years**.



Find out more about our offer

RIGID - 6 BATTERIES

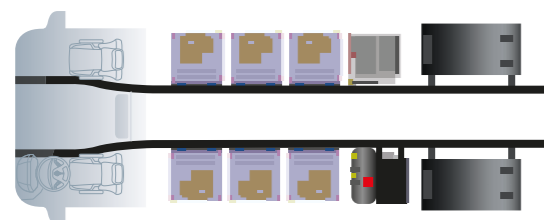

→ Available on Day cab
6 batteries / 2 or 3 motors

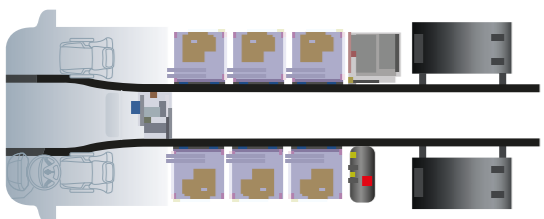

→ Available on long cabs
6 batteries / 2 or 3 motors

Minimum wheelbase (mm)		
Type	Day cab	Long cab
4x2	4900	4900
6x2	4600	4800
8x4		4900

RIGID - 5 BATTERIES

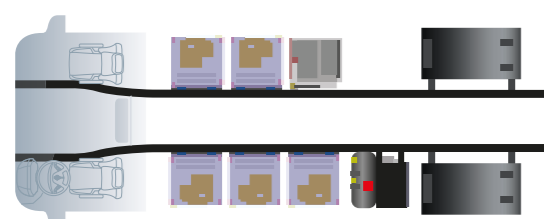

→ Available on Day cab
5 batteries / 2 or 3 motors

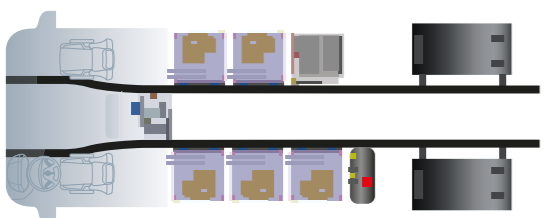

→ Available on long cabs
5 batteries / 2 or 3 motors

Minimum wheelbase (mm)		
Type	Day cab	Long cab
4x2	4600	4600
6x2		4300
8x4		

A large choice of electric motors and traction batteries

RIGID - 4 BATTERIES

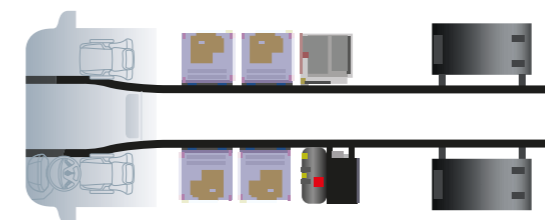

→ Available on Day cab
4 batteries / 2 motors

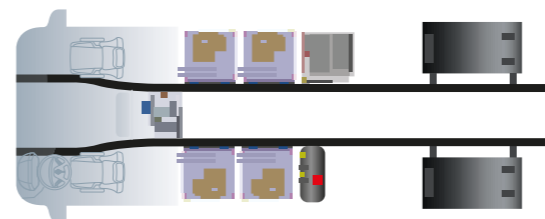

→ Available on long cabs
4 batteries / 2 motors

Minimum wheelbase (mm)		
Type	Day cab	Long cab
4x2	4100	4100
6x2	3900	
8x4		

TRACTOR - 6 OR 5 BATTERIES

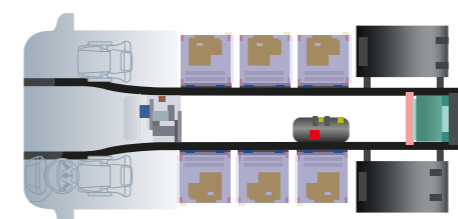

→ Available on long cabs
6 batteries / 3 motors

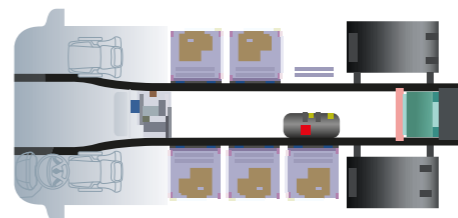

→ Available on long cabs
5 batteries / 3 motors

Minimum wheelbase (mm)	
Type	Long cab
4x2	3900

Proven Technology



Technical expertise in batteries

Lithium-Ion NCA technology cells supplied by Samsung. Batteries assembled in the Volvo Group factory of Ghent in Belgium.



Responsible supply chain

Supply chain audits are conducted to minimise the environmental and societal impact of our suppliers as well as their own suppliers (e.g.: Cobalt). The batteries are assembled in Ewrope. The vehicles are assembled in France.



Responsible recycling

Recycling is the responsibility of Renault Trucks as soon as the batteries are returned to Renault Trucks authorised dealers. There is a range of second life options for vehicle batteries, such as stationary energy storage equipment or energy supply for buildings (hospitals, stadiums, housing, etc.).



3 types of power take-off for a simplified body structure

Gearbox PTO

- 5 Torque capacity from 430 Nm to 1000 Nm
- Same offer as diesel
- Flange or pump output
- Single or dual output
- Usable when vehicle is stationary (up to 7km/h)

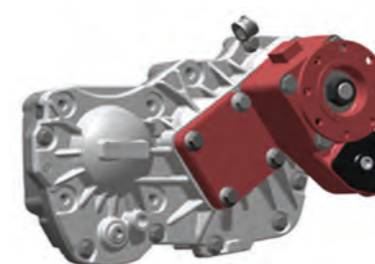

Mechanical E-PTO

- Electric Motor 70 kW
- Torque capacity 270 Nm
- Pump output
- Above the frame behind the cab
- 4 wiring lengths available to enable body builder repositioning
- Usable when vehicle is moving (in place of diesel engine PTO)



Electrical E-PTO

- Power 43 kW
- AC or DC output
- AC E-PTO:
 - available for tractor and rigid
 - voltage 400-480V AC
- DC E-PTO:
 - available for rigid only
 - voltage 600-800V DC



Available wheelbases (mm)

		3900	4100	4300	4600	4800	4900	5200	5600	6000	6500	6700
RIGID	4x2		■	■	■		■	■	■	■	■	■
	6x2	■	■	■	■	■	■	■	■	■		
	8x4 Tridem	■	■	■	■		■	■				
TRACTOR	4x2	■										



Cab types

Day cab



Night & Day cab*

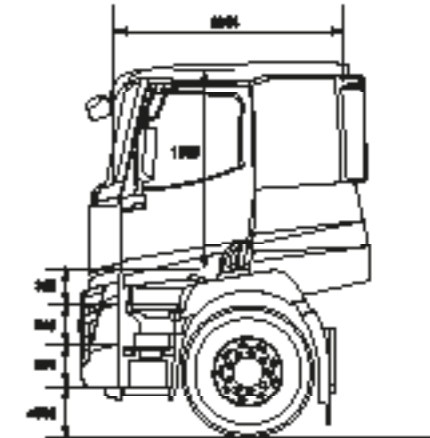

Sleeper cab*

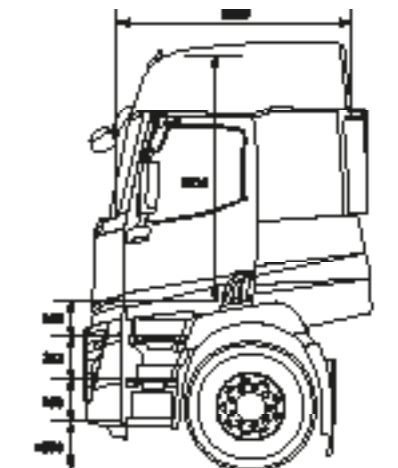

* Long cab



05/2023

Dimensions and characteristics are only indicative.
The manufacturer reserves the right to modify them without notice.
Renault Trucks SAS with a capital of € 50,000,000 - 954 506 077 RCS



**RENAULT
TRUCKS**

renault-trucks.co.uk